

Rozměry v mm
Maße in mm
Dimensions in mm

IMPRESSION L 2g L 71.60.34.21

IMPRESSION L 2g L 71.60.34.21 + IR2LG TOP01

IMPRESSION L 2g L 71.60.34.21 + IR2LG TOP02

221kg

293kg

283kg

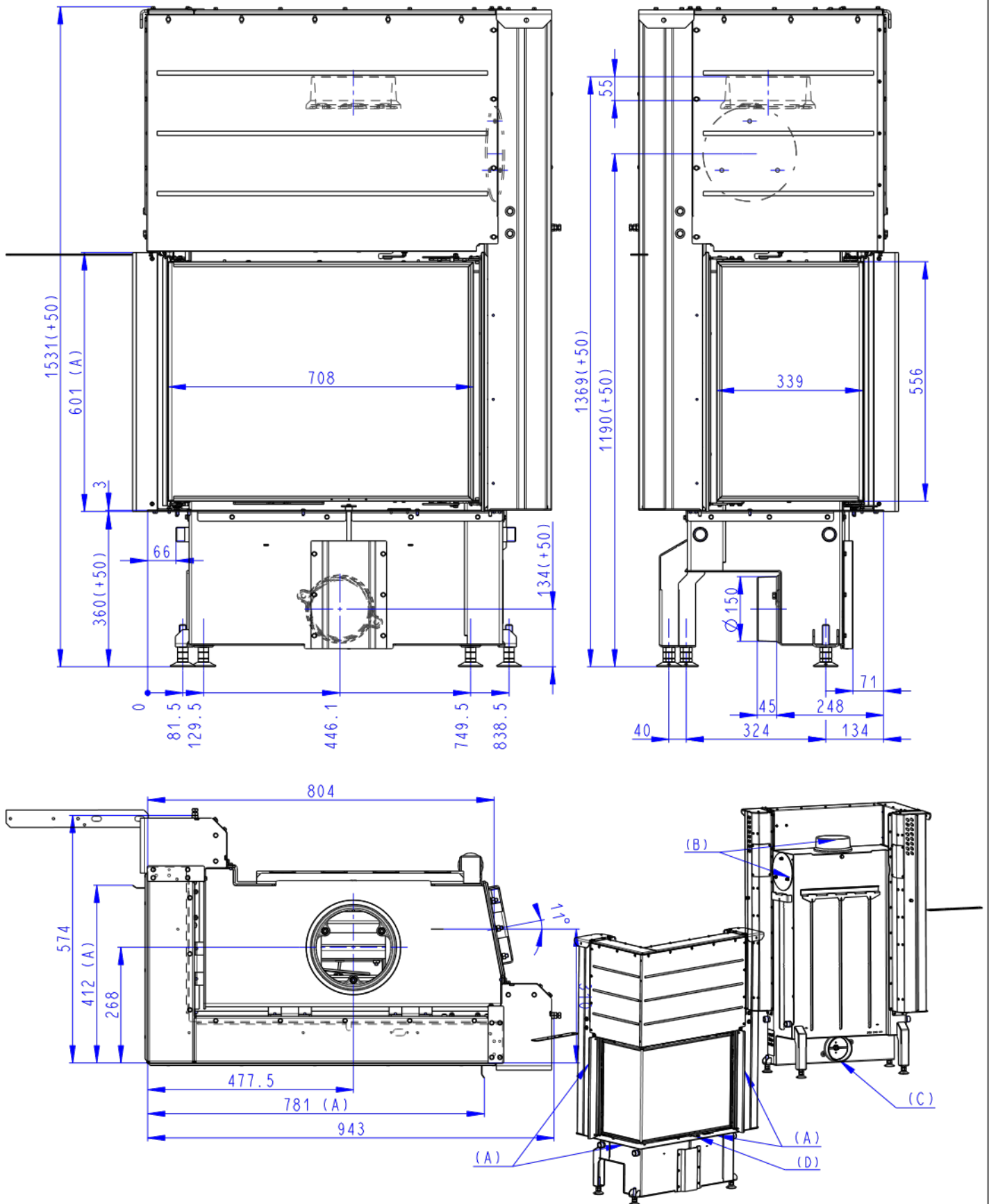

(A) Zastavbový rozmer / Baumaße / In-built dimension

(B) Litinový odvod kouře / Cast iron spigot / Der gusseiserne Rauchabgang

(C) Centralní privod vzduchu / Central air inlet / Zentralluftzufuhr

(D) Primární a sekundární vzduch / Primary and secondary air / Primärluft und Sekundärluft

Rozměry v mm
Maße in mm
Dimensions in mm

IMPRESSION R 2g L 71.60.34.21

IMPRESSION R 2g L 71.60.34.21 + IR2LG TOP01

IMPRESSION R 2g L 71.60.34.21 + IR2LG TOP02

221kg

293kg

283kg

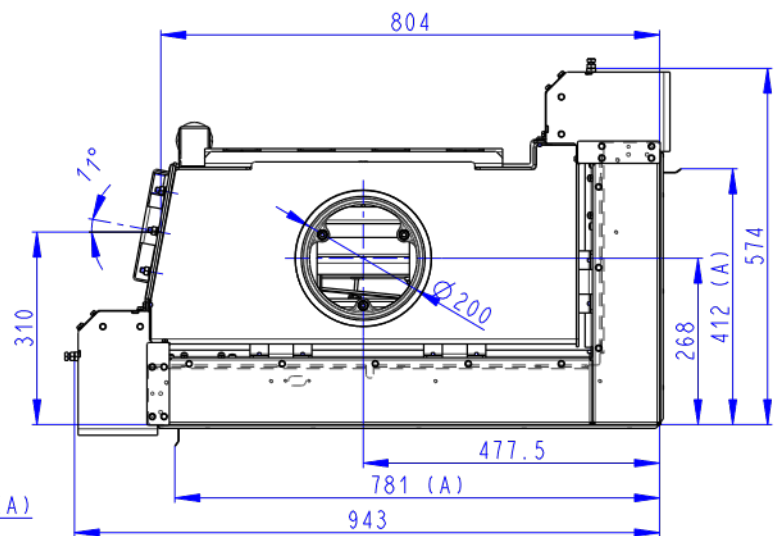
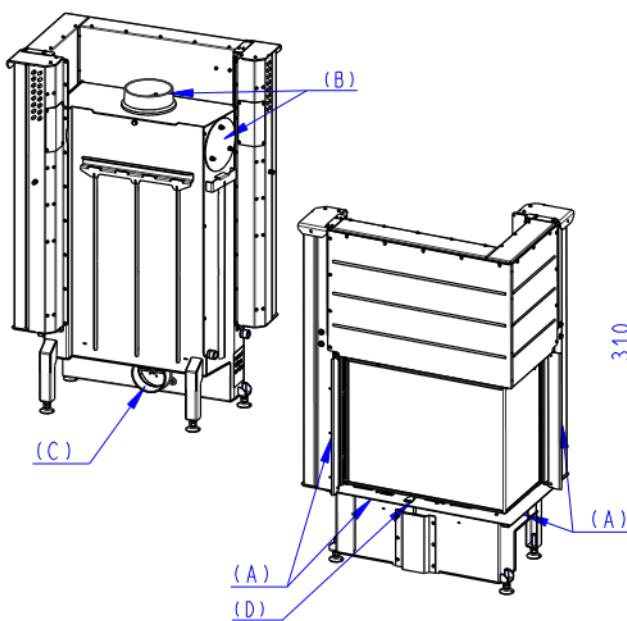
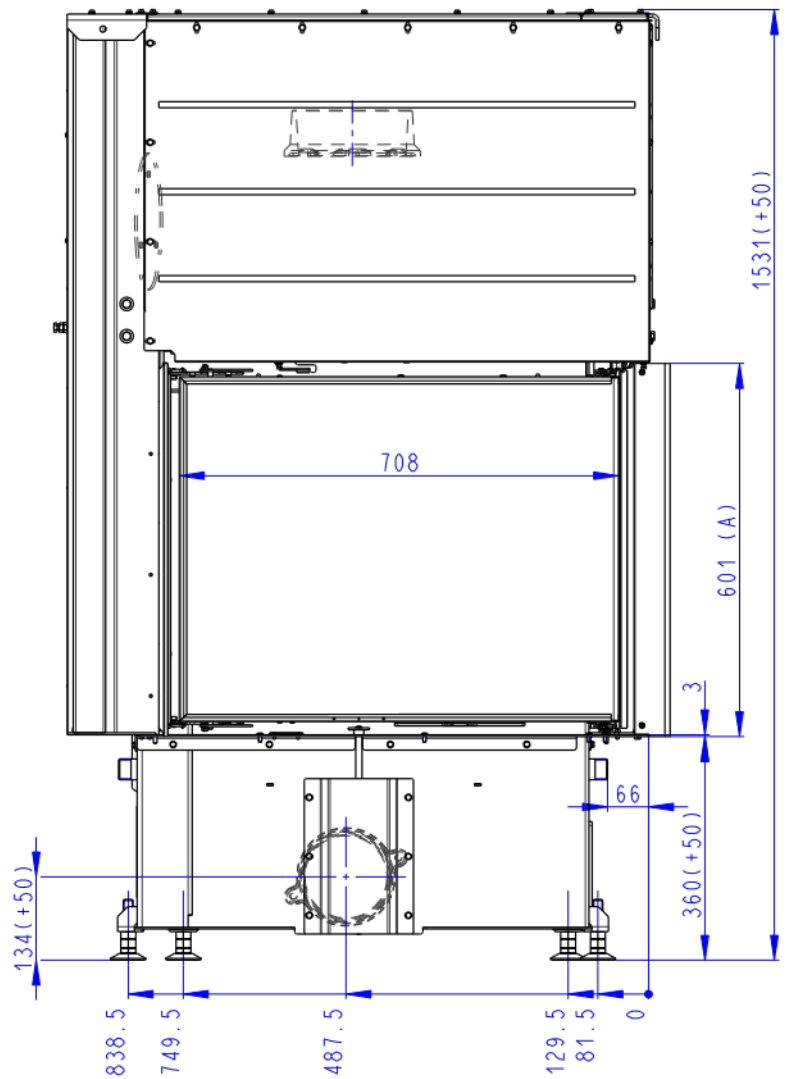
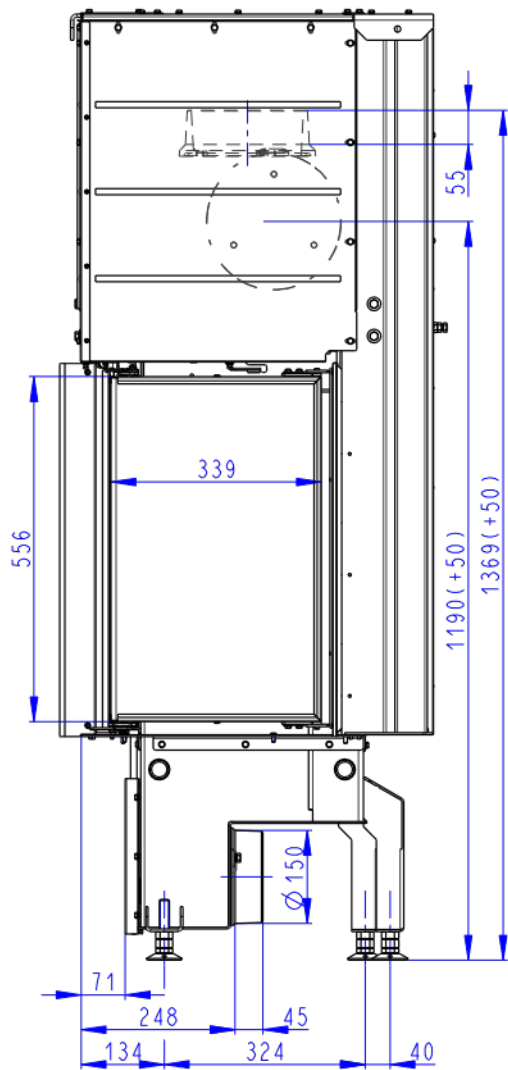

- (A) Zastavbovy rozmer / Baumaße / In-built dimension
(B) Litinový odvod kouře / Cast iron spigot / Der gusseiserne Rauchabgang
(C) Centralní privod vzduchu / Central air inlet / Zentralluftzufuhr
(D) Primární a sekundární vzduch / Primary and secondary air / Primärluft und Sekundärluft