

Rozměry v mm
Maße in mm
Dimensions in mm

IMPRESSION L 2g S 58.60.34.21

113kg

IMPRESSION L 2g S 58.60.34.21 + IR2LF TOP01

174kg

IMPRESSION L 2g S 58.60.34.21 + IR2LF TOP02

166kg

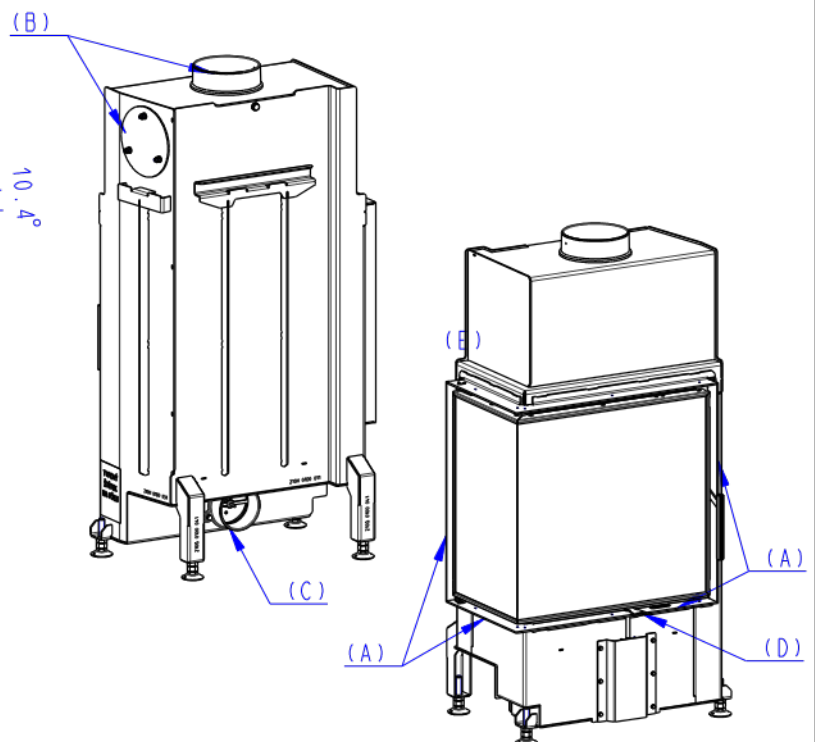
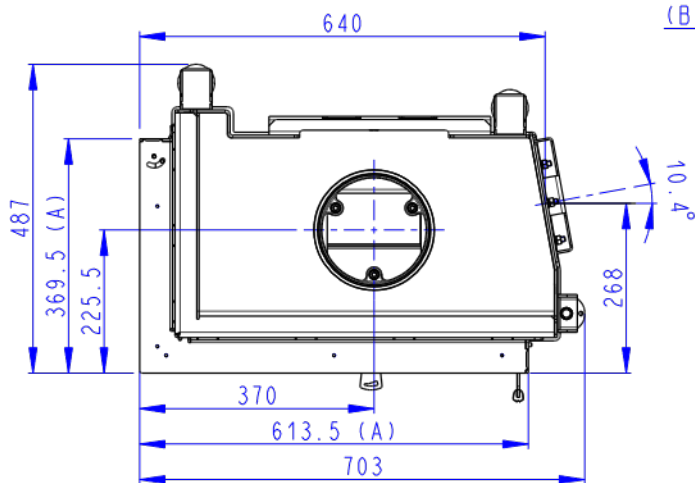
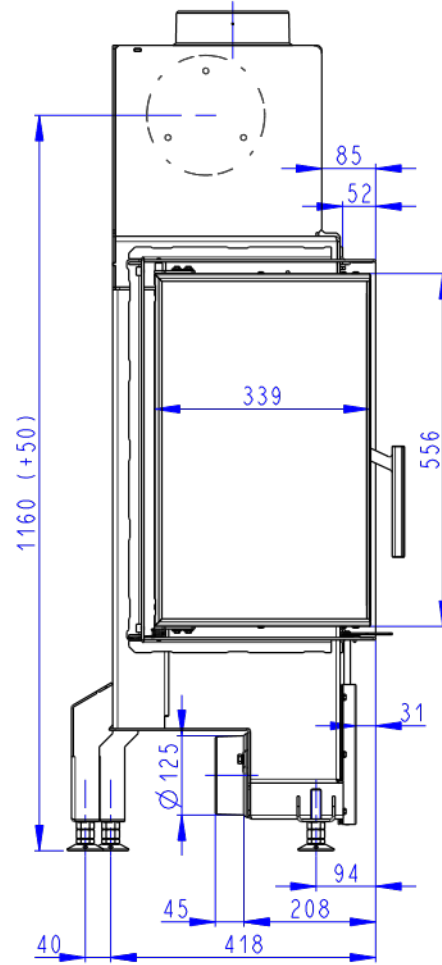
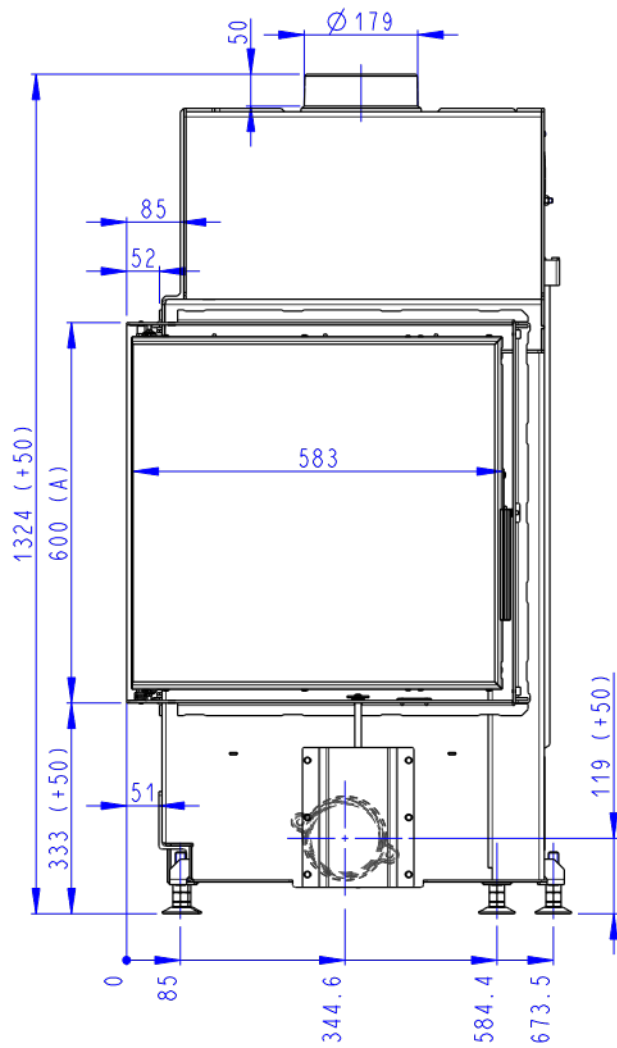

- (A) Zastavbovy rozmer / Baumaße / In-built dimension
- (B) Litinový odvod kouře / Cast iron spigot / Der gusseiserne Rauchabgang
- (C) Centralní privod vzduchu / Central air inlet / Zentralluftzufuhr
- (D) Primární a sekundární vzduch / Primary and secondary air / Primärluft und Sekundärluft

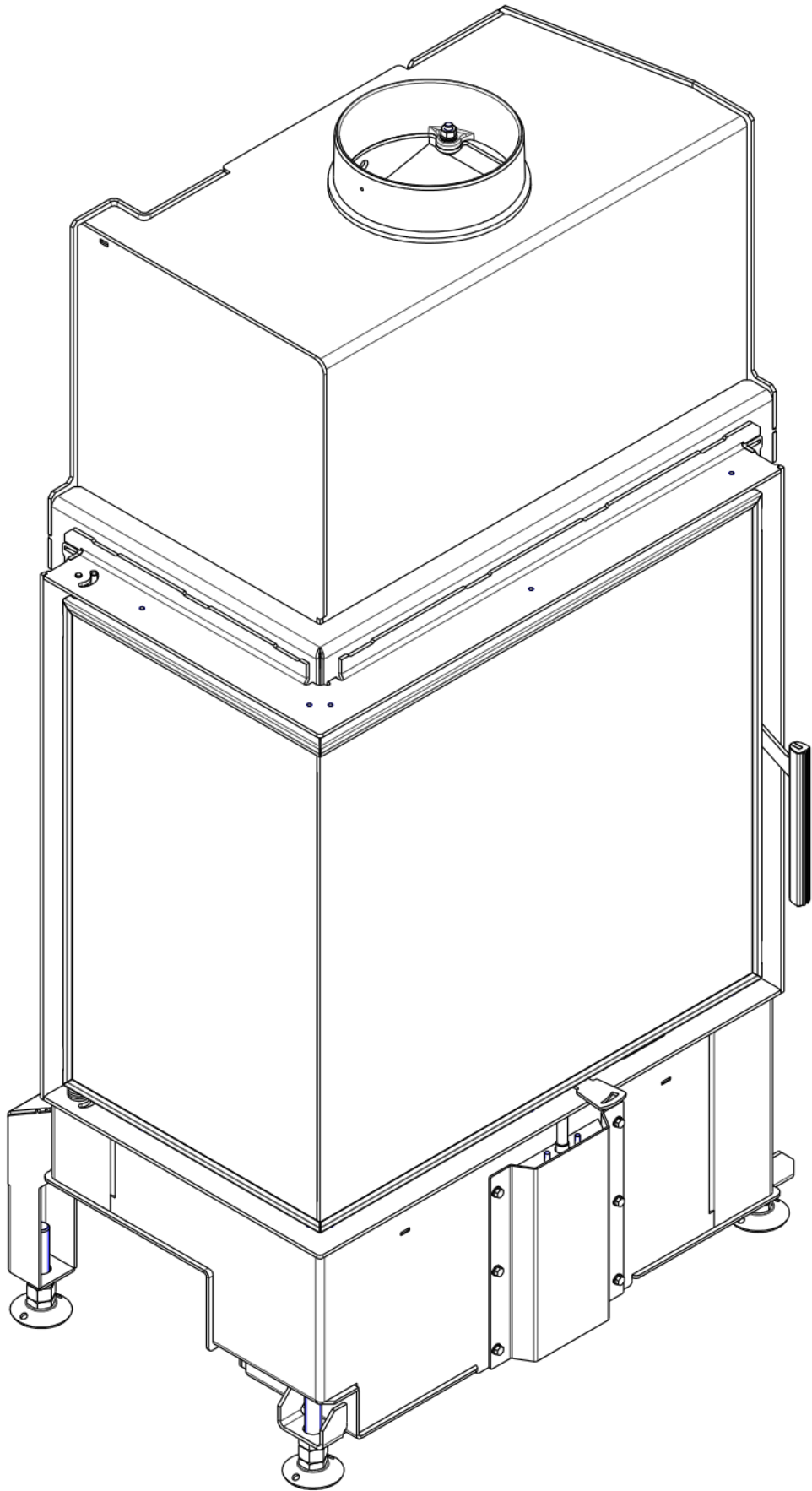

Rozměry v mm
 Maße in mm
 Dimensions in mm

| | |
|---|-------|
| IMPRESSION R 2g S 58.60.34.21 | 113kg |
| IMPRESSION R 2g S 58.60.34.21 + IR2LF TOP01 | 174kg |
| IMPRESSION R 2g S 58.60.34.21 + IR2LF TOP02 | 166kg |

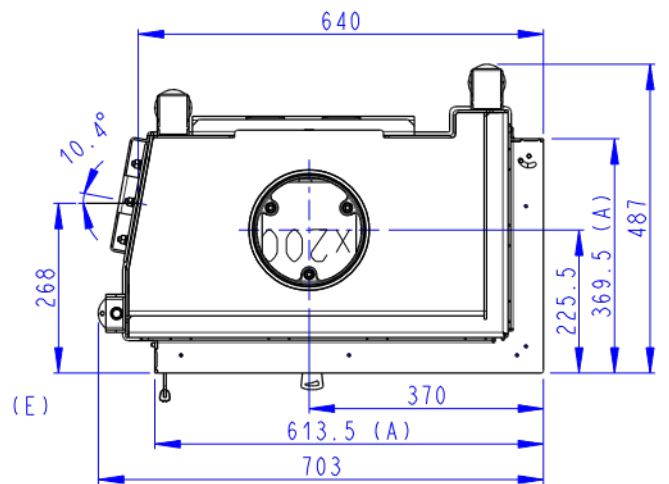
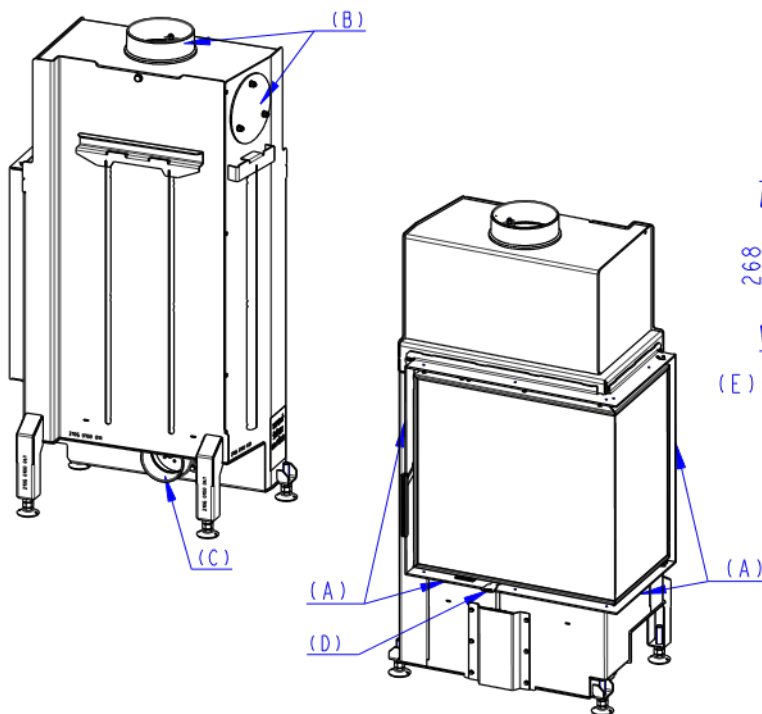
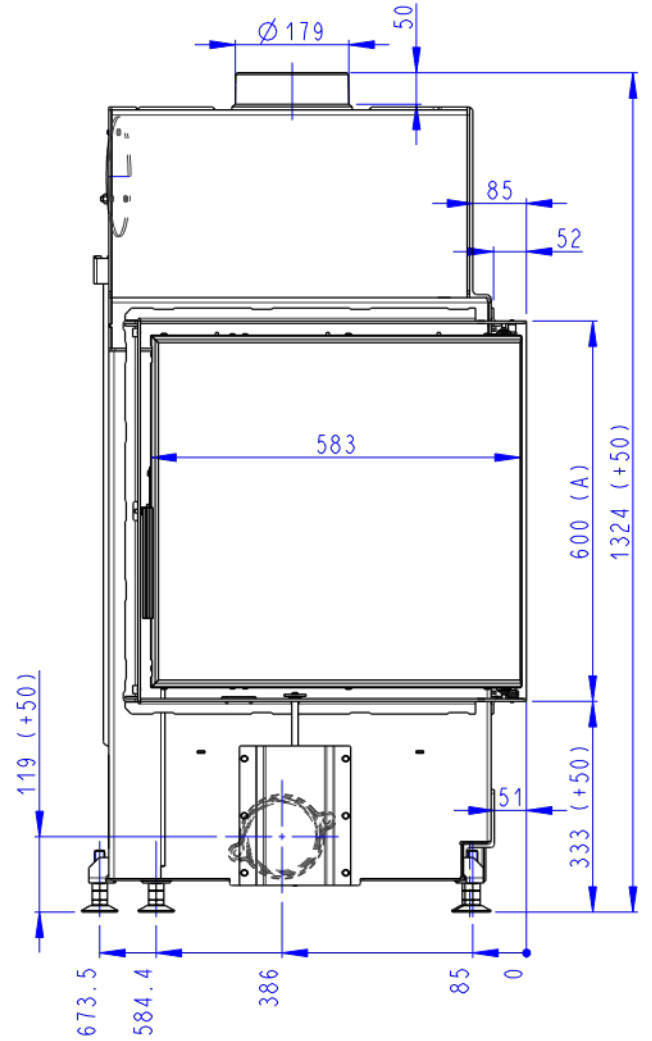
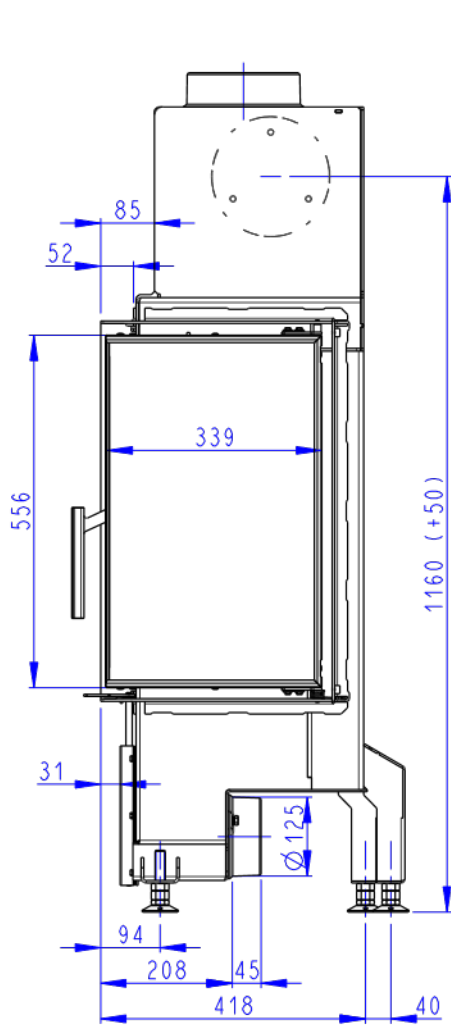

- (A) Zastavbovy rozmer / Baumaße / In-built dimension
- (B) Litinový odvod kouře / Cast iron spigot / Der gusseiserne Rauchabgang
- (C) Centralni privod vzduchu / Central air inlet / Zentralluftzufuhr
- (D) Primarni a sekundarni vzduch / Primary and secondary air / Primärluft und Sekundärluft

